

MAXIM

MAX1966 Evaluation Kit

General Description

The MAX1966 evaluation kit (EV kit) is a fully assembled and tested circuit board that contains two independent step-down DC-to-DC converter circuits.

The MAX1966 circuit is optimized for a 3V to 5.5V input range and delivers 1.8V at 2A. The MAX1967 circuit is optimized for a 4.9V to 20V input range and delivers 2.5V at 2A. Refer to the MAX1966/MAX1967 data sheet for component selection for higher current applications.

Features

- ◆ Lowest Cost Solution
- ◆ Up to 96% Efficiency
- ◆ Evaluates MAX1966/MAX1967
- ◆ 3V to 5.5V Input Range (MAX1966 Circuit)
1.8V at 2A Output
- ◆ 4.9V to 20V Input Range (MAX1967 Circuit)
2.5V at 2A Output
- ◆ Fully Assembled and Tested

Ordering Information

PART	TEMP RANGE	PIN-PACKAGE
MAX1966EVKIT	0°C to +70°C	8 SO/10 μ MAX

Component List

DESIGNATION	QTY	DESCRIPTION
C1, C8, C9, C16	4	0.1 μ F \pm 20%, 50V X7R ceramic capacitors (0805) Taiyo Yuden UMK212BJ104MG
C2, C10	2	330 μ F \pm 20%, 35V aluminum electrolytic capacitors (10 x 20) Sanyo 35MV330AX
C3, C11	0	Not installed capacitors (10 x 16)
C4, C5, C12, C13	4	820 μ F \pm 20%, 10V aluminum electrolytic capacitors (10 x 16) Sanyo 10MV820AX
C6, C14, C18	3	1 μ F \pm 20%, 10V X7R ceramic capacitors (0805) Taiyo Yuden LMK212BJ105MG
C7	1	3300pF \pm 20%, 50V X7R ceramic capacitor (0603) Taiyo Yuden UMK107B332MZ
C15	1	0.01 μ F \pm 20%, 50V X7R ceramic capacitor (0603) Taiyo Yuden UMK107B103MZ
C17	1	2.2 μ F \pm 20%, 10V X5R ceramic capacitor (0805) Taiyo Yuden LMK212BJ225MG
C19	1	1 μ F \pm 10%, 25V, X7R ceramic capacitor (0805) TDK C2012X7R1E105K

DESIGNATION	QTY	DESCRIPTION
D1, D2	2	100mA, 30V Schottky diodes SOT23 Central Semiconductor CMPSH-3
D3, D4	2	100mA, 30V Schottky diodes SOT323 Central Semiconductor CMSSH-3
L1, L2	2	22 μ H, 2.5A inductors Coilcraft TV1415-B or Transpower Technologies, Inc. LCI-1
N1, N2	2	3.5A, 30V dual N-channel MOSFETs, 8-pin SO Fairchild Semiconductor FDS6961A
R1	1	1.24k Ω \pm 1% resistor (0805)
R2, R5	2	1k Ω \pm 1% resistors (0805)
R3	1	182k Ω \pm 1% resistor (0805)
R4	1	2.10k Ω \pm 1% resistor (0805)
R6	1	75k Ω \pm 1% resistor (0805)
R7, R8	0	Not installed resistors (0805)
R9–R12	4	10 Ω \pm 1% resistors (0603)
U1	1	MAX1966ESA, 8-pin SO
U2	1	MAX1967EUB, 10-pin μ MAX
None	1	MAX1966 PC board

Evaluates: MAX1966/MAX1967

MAX1966 Evaluation Kit

Component Suppliers

SUPPLIER	PHONE	FAX	WEBSITE
Central Semiconductor	631-435-1110	631-435-1824	www.centrasemi.com
Coilcraft	847-639-6400	847-639-1469	www.coilcraft.com
Fairchild Semiconductor	888-522-5372	972-910-8036	www.fairchildsemi.com
Sanyo	619-661-6322	619-661-1055	www.sanyovideo.com
Taiyo Yuden	800-348-2496	847-925-0899	www.t-yuden.com
TDK	847-803-6100	847-390-4405	www.component.tdk.com
Transpower Technologies, Inc.	775-852-0140	775-852-0145	www.trans-power.com

Note: Please indicate that you are using the MAX1966 when contacting these component suppliers.

Quick Start

The MAX1966 EV kit is fully assembled and tested. Follow these steps to verify board operation. **Do not turn on the power supply until all connections are completed.**

Required Equipment

The following equipment is required before beginning:

- 20V, 2ADC power supply
- One voltmeter

VOUT1 (MAX1966)

- 1) Connect a voltmeter to the VOUT1 pad.
- 2) Connect a 3VDC to 5.5VDC power supply to the VIN1 pad, with the voltage set to 0V.
- 3) Connect the supply ground to the GND pad near VIN1.
- 4) Turn on the power supply and gradually increase the input voltage through the 3V to 5.5V range.
- 5) Verify that VOUT1 is 1.8V throughout the 3V to 5.5V input voltage range.

VOUT2 (MAX1967)

- 1) Connect a voltmeter to the VOUT2 pad.
- 2) Connect a 4.9VDC to 20VDC power supply to the VIN2 pad, with the voltage set to 0V.
- 3) Connect the supply ground to the GND pad near VIN2.
- 4) Turn on the power supply and gradually increase the input voltage through the 4.9V to 20V range.
- 5) Verify that VOUT2 is 2.5V throughout the 4.9V to 20V input voltage range.

Detailed Description

The MAX1966 EV kit contains two step-down DC-DC converters. One of the circuits uses a MAX1966, an 8-pin SO step-down controller. The other circuit uses a MAX1967, a 10-pin μ MAX step-down controller. Both evaluation circuits are designed to achieve the lowest component cost.

The MAX1966 evaluation circuit has a 3V to 5.5V input range. The output is configured for 1.8V that can supply up to 2A. The MAX1967 evaluation circuit has a higher input range of 4.9V to 20V. The output is configured for 2.5V and can supply up to 2A. Both circuits have extra pads for additional input capacitors to reduce input ripple current.

The switching frequencies for both the MAX1966/MAX1967 are internally set at 100kHz. The circuits use a feedback voltage of 0.8V and offer efficiencies up to 96%.

Other Output Voltages

The MAX1966 EV kit comes preset to 1.8V on VOUT1, and 2.5V on VOUT2. To set other output voltages, refer to the MAX1966/MAX1967 data sheet for external component selection.

MAX1966 Evaluation Kit

Evaluates: MAX1966/MAX1967

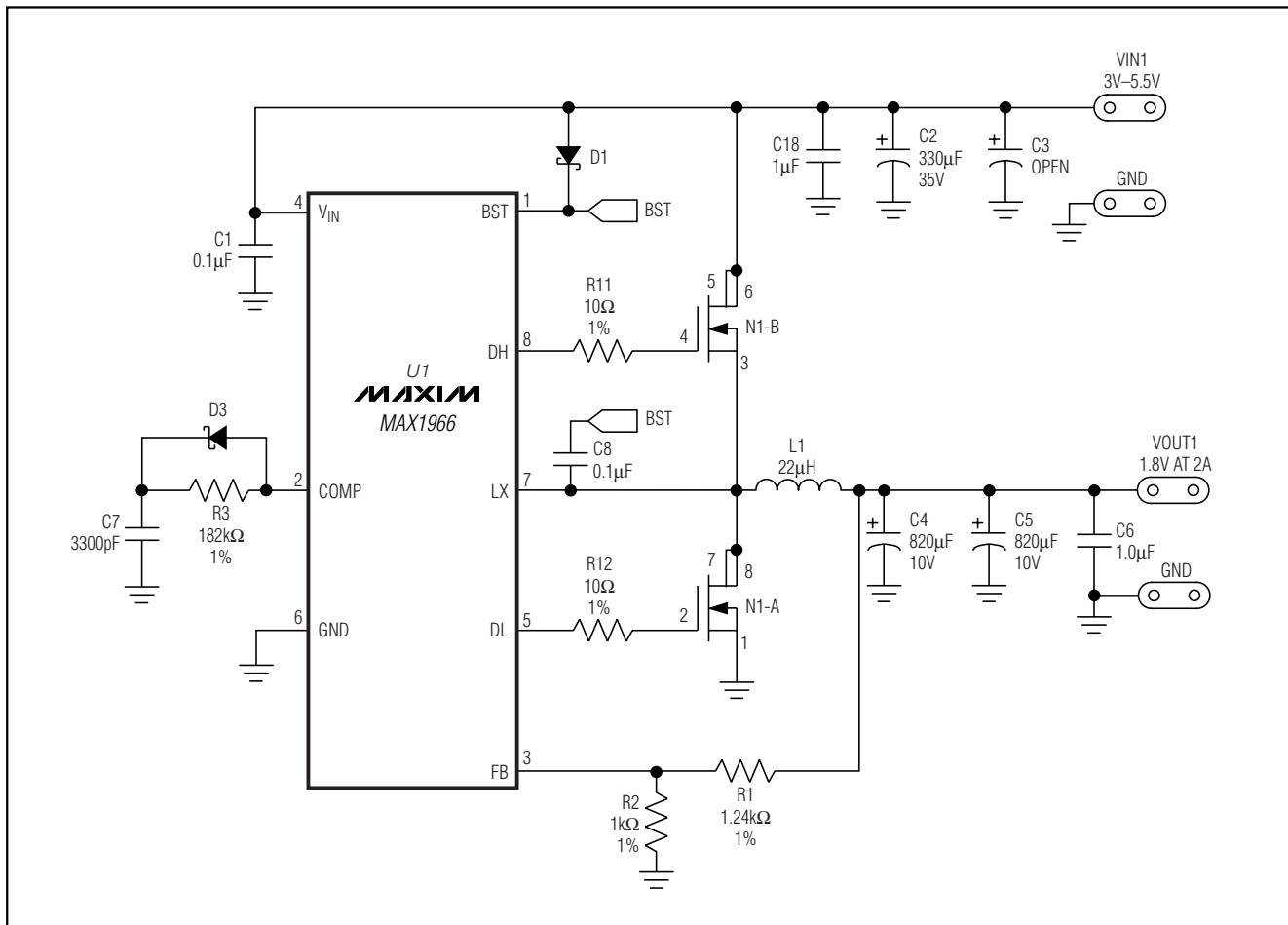

Figure 1. MAX1966 EV Kit Schematic (Evaluating MAX1966)

MAX1966 Evaluation Kit

Evaluates: MAX1966/MAX1967

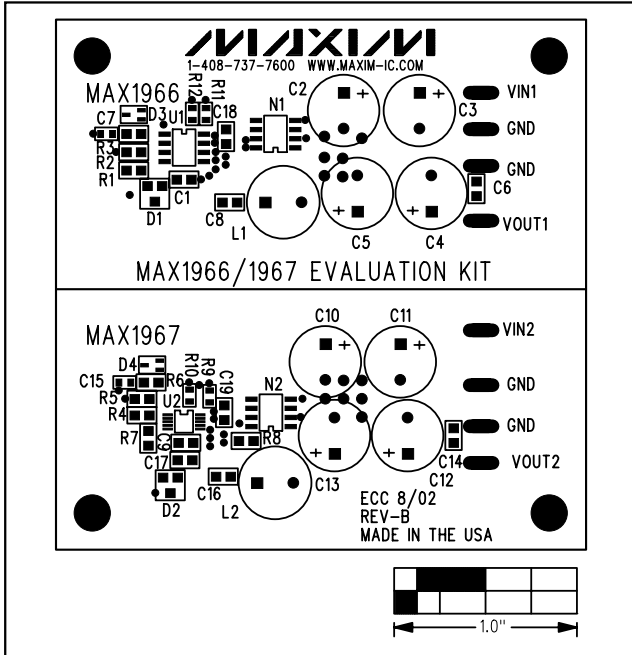

Figure 3. MAX1966 EV Kit Component Placement Guide—Component Side

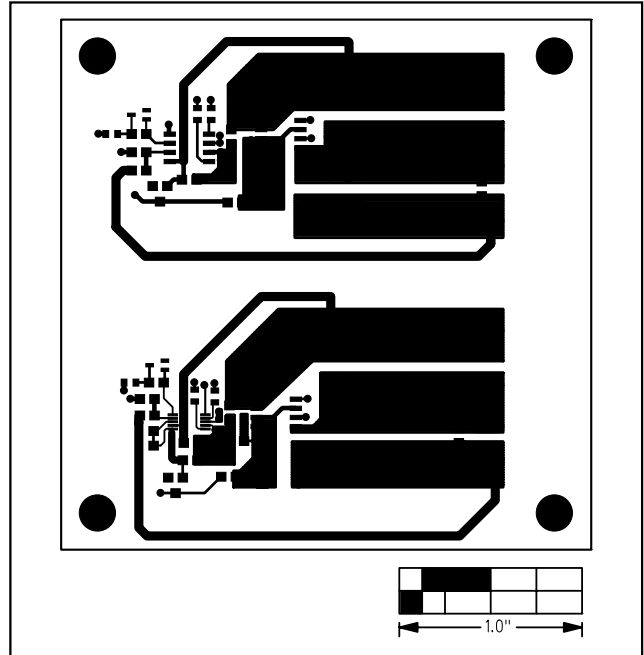

Figure 4. MAX1966 EV Kit PC Board Layout—Component Side

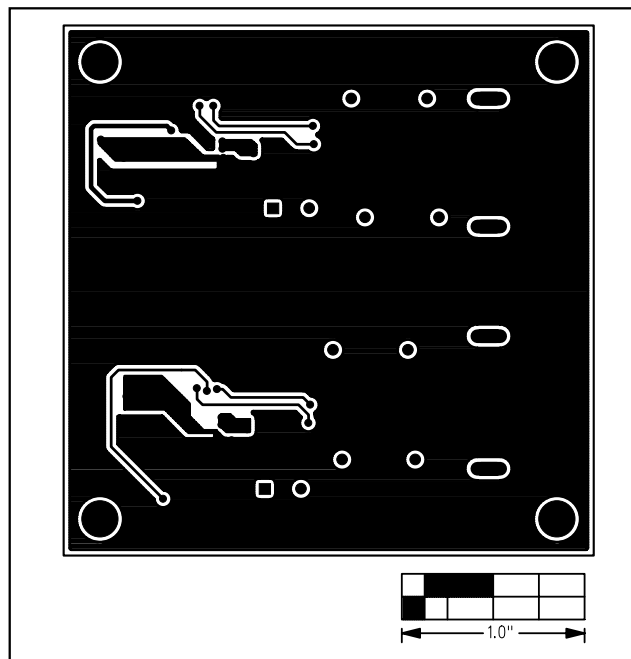

Figure 5. MAX1966 EV Kit PC Board Layout—Solder Side

Maxim cannot assume responsibility for use of any circuitry other than circuitry entirely embodied in a Maxim product. No circuit patent licenses are implied. Maxim reserves the right to change the circuitry and specifications without notice at any time.

Maxim Integrated Products, 120 San Gabriel Drive, Sunnyvale, CA 94086 408-737-7600 _____ 5